

Here is the schematic diagram for this kit:

A schematic diagram is a drawing that shows how all of the components are connected in order to understand the operation of the circuit. As you learn more about electronics you will start to recognize some of these symbols. It is almost like a roadmap to show where all the houses are and how the streets are connected to each other.

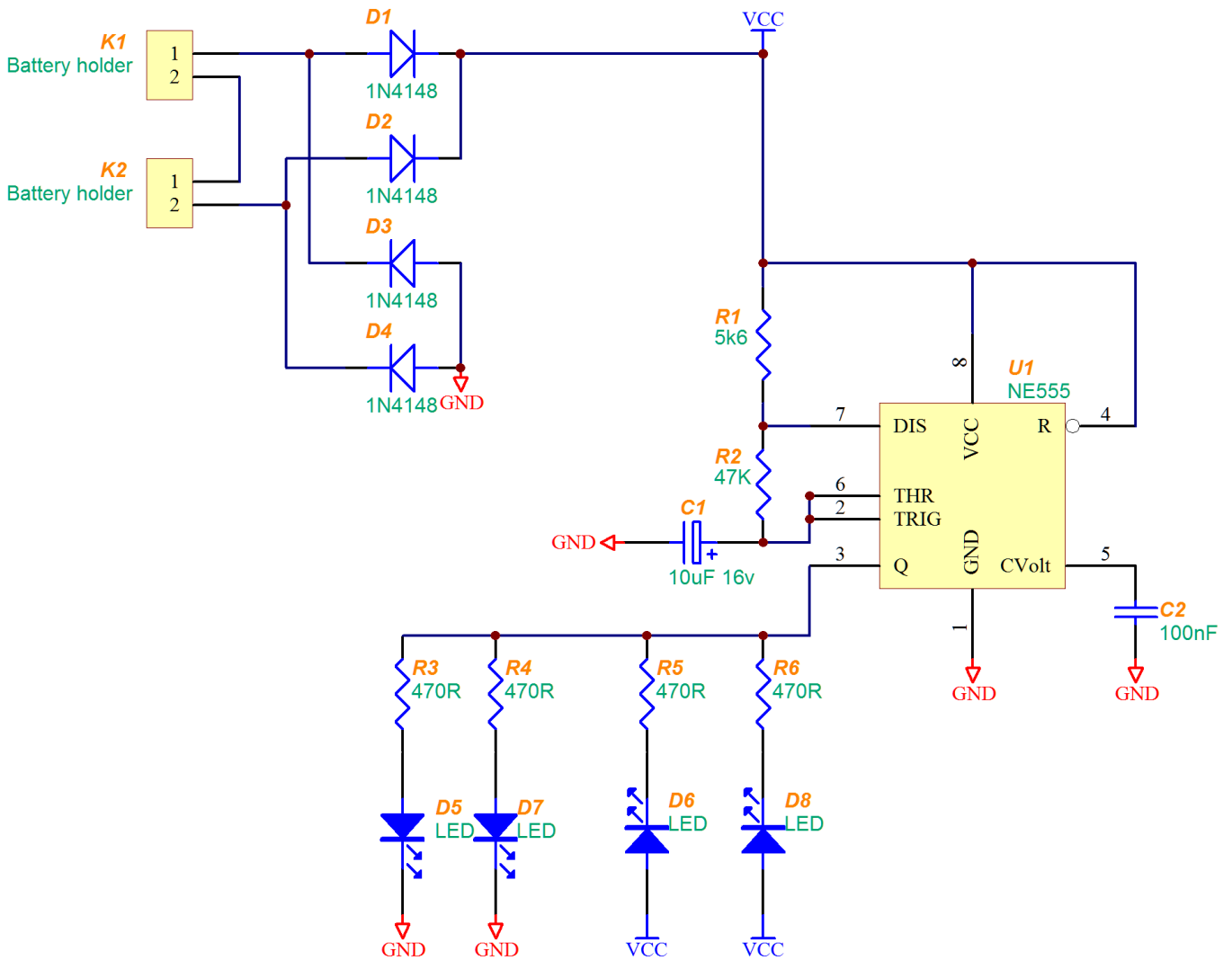

Detailed Description:

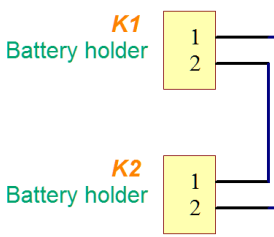

K1 and K2 are the battery holders.

They are wired so that the batteries are all in series. Each battery is about 1.5volts, and when we connect them in series, we end up with $1.5 \times 4 = 6$ volts.

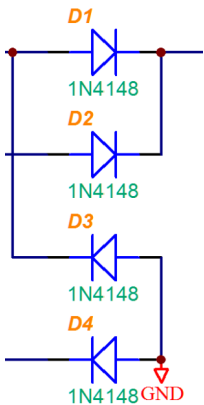

D1,D2,D3,D4 are diodes. Diodes are components that let current go in one direction only. In this circuit we use 4 of them to create a bridge rectifier, so that the circuit can be protected if you maybe put the batteries in the wrong way.

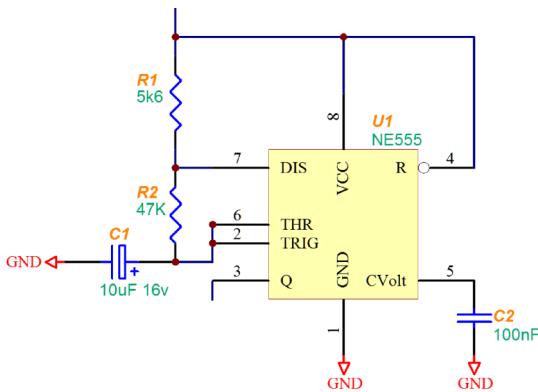

U1 is the heart of the project. The 555 Timer is connected in a way that creates an oscillator, which is something that goes on and off, just like your own heart. R1 and R2 and C1 control the timing of the oscillator to make it go faster or slower. The oscillator output signal is at pin 3. C2 is there to stabilize the oscillator. (To keep the timing consistent)

If you make the value of R1 and R2 smaller, the oscillator will run faster.

If you make the value of C1 smaller, the oscillator will also run faster.

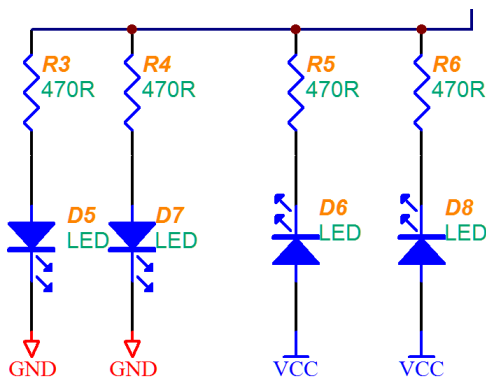

D5,D6,D7,D8 are LEDs. LEDs are Light Emitting Diodes. They make light when current goes through them. We have two of them (D5 and D7) connected to light up when Pin3 of U1 turns ON, and we have another two (D6 and D8) connected to light up when Pin3 of U1 turns OFF. This way we have two sets of LEDs flashing.

R3,R4,R5,R6 are resistors to protect the LED to have only the correct amount of electric current flowing through the LEDs. IF you make the value of these resistors smaller they will have LESS resistance and the LEDs will shine brighter.

Check out the instruction video on Youtube here:

What do you need?

- 1: Solder iron
- 2: Solder wire
- 3: Side cutters
- 4: Your HyperTronics kit
- 5: Batteries

Step 1: Make sure you have everything. Compare the Parts list with your kit and make sure that all the components that are shown on the Parts list, is in your kit. Some of the parts are on the Component sheet, and some of them may be loose in the package.

Step 2: Mount the components in the same order as they appear in the Parts list. We mount the larger components first. Stick the leads of the component through the Printed Circuit board, and we solder them on the other side. After soldering, we cut off the leads that are long.

Step 3: Make sure everything is correctly done. Maybe ask your mom or dad to have a look. Compare your completed printed Circuit board with the pictures included with your kit. **If it is not done correctly and you turn it on, it will not work and it is possible that you can break something.**

Step 4: Install the batteries and have fun!!

Troubleshooting: What must I do if it does not work?





- 1: Take out the batteries
- 2: Check that you have all the components soldered
- 3: Check that all the components are the right way in
- 4: Check that you do not have solder that is bridging two pads.

HT001 Parts List



LEARNING BY DOING

| Designator | Part Description | Picture | Marking | Notes to the Young Engineer |
|-------------|---------------------------------|--|---------------------------|--|
| R1 | 5.6Kohm Resistor 1/4Watt Leaded |  | Green-Blue-Red-Gold | Can go in any direction |
| R2 | 47Kohm Resistor 1/4Watt Leaded |  | Yellow-Violet-Orange-Gold | Can go in any direction |
| R3,R4,R5,R6 | 470ohm Resistor 1/4Watt leaded |  | Yellow-Violet-Brown-Gold | Can go in any direction |
| C1 | 10uF Electrolytic Capacitor |  | 10uF | BE CAREFUL which way you put it in! |
| C2 | 100nF Ceramic Capacitor |  | 104 | Can go in any direction |
| D1,D2,D3,D4 | 1N4148 Diode |  | Black band | BE CAREFUL which way you put it in! |
| D5,D6,D7,D8 | Red LED 5mm |  | Flat side / Short pin | BE CAREFUL which way you put it in! |
| U1 | NE555 Integrated Circuit |  | NE555 | BE CAREFUL which way you put it in! |
| K1, K2 | AAA Battery holder |  | 2xAAA | |

Pictures

Use these pictures to **DOUBLE CHECK** that you have everything done correctly **BEFORE** putting in the batteries!!



Component side

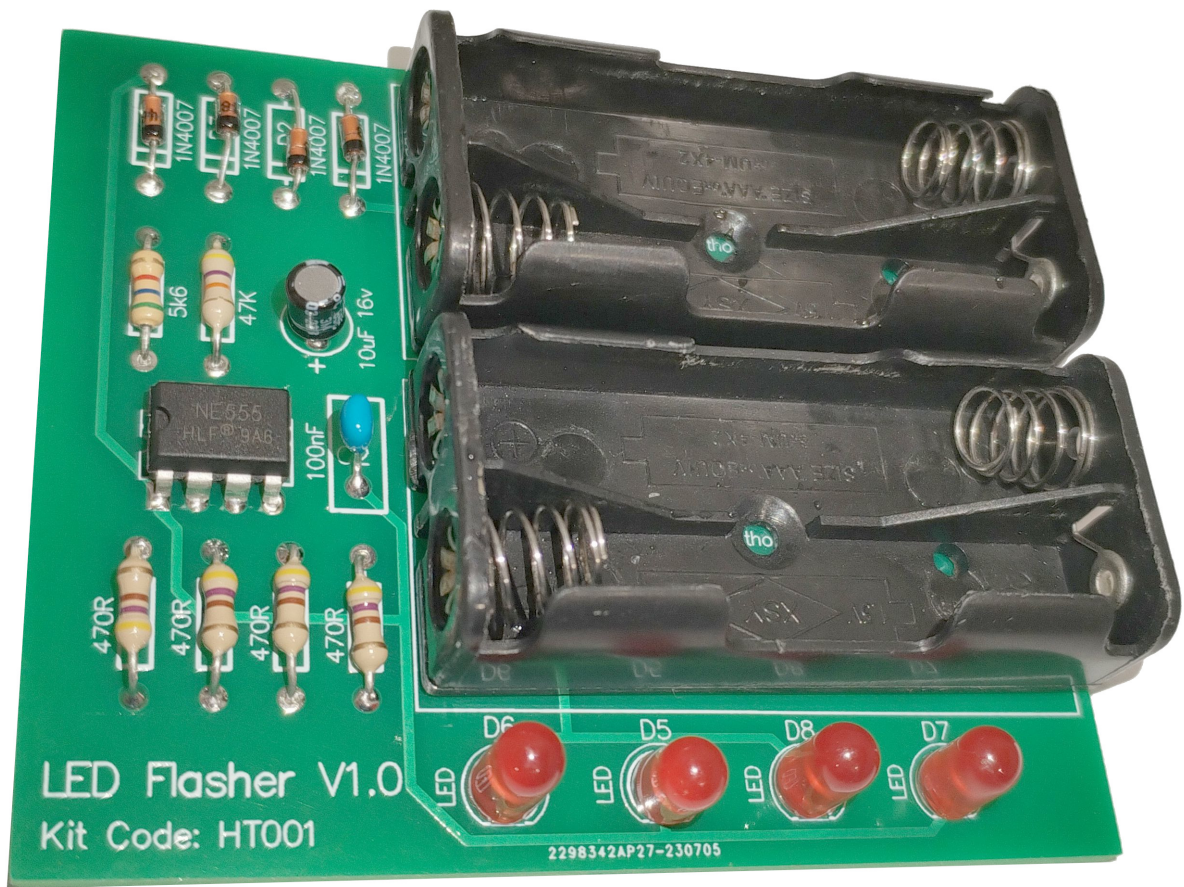

Solder side

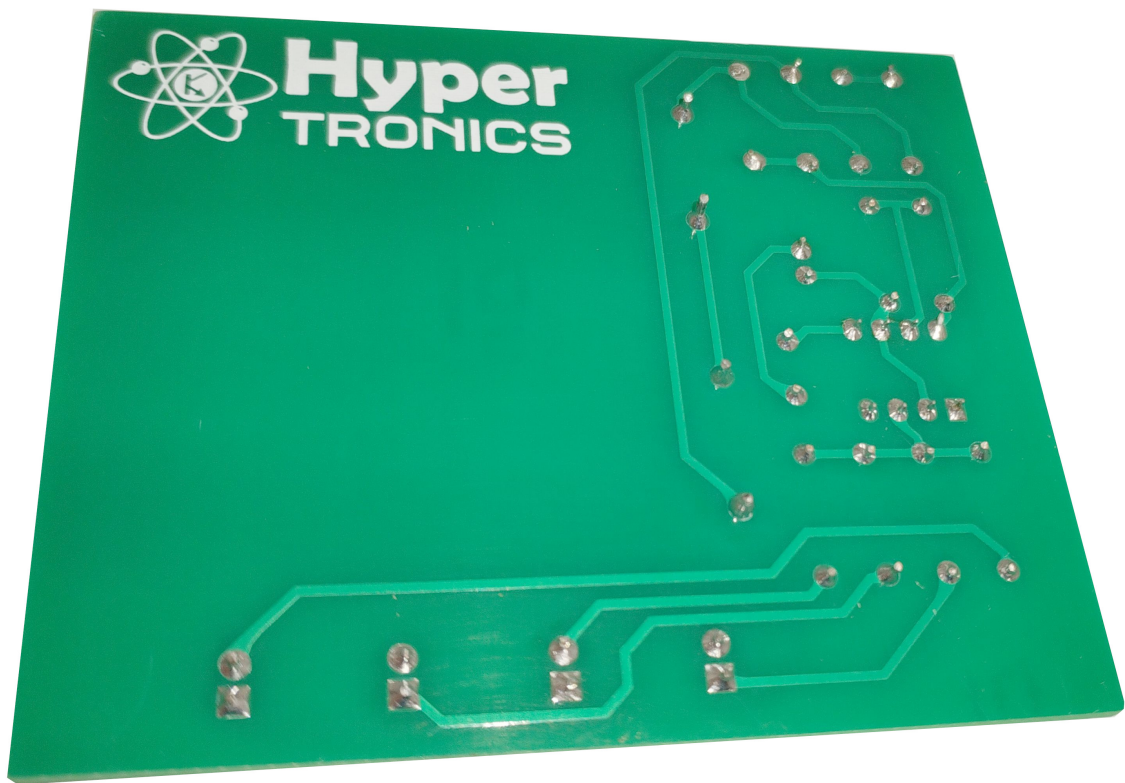

What to do if it is not correct?

DO NOT switch it on.

You will need to fix it to look the same as the picture before switching on.